

Owner's Manual

Amplified Receiver Module

Model **ES-1A** / Model **ES-2A**



Introduction

Thank you for utilising NetCIRA by Fostex model ES-1A / ES-2A.

Both ES-1A and ES-2A are NetCIRA network receiver modules. The units can be set to receive and decode audio data for either one (ES-1A) or two (ES-2A) channels from a total of 64 digital audio channels transmitted from model MS-8 (8 channel master/slave unit) and other compatible products using the EtherSound network audio protocol. The decode analog audio is amplified by the internal power amplifier of the ES-1A / ES-2A.

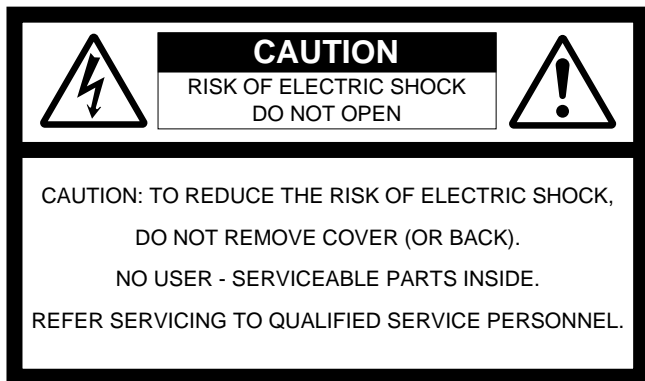

"WARNING"

"TO REDUCE THE RISK OF FIRE OR ELECTRIC SHOCK, DO NOT EXPOSE THIS APPLIANCE TO RAIN OR MOISTURE."

SAFETY INSTRUCTIONS

1. Read Instructions - All the safety and operating instructions should be read before the appliance is operated.
2. Retain Instructions - The safety and operating instructions should be retained for future reference.
3. Heed Warnings - All warnings on the appliance and in the operating instructions should be adhered to.
4. Follow Instructions - All operating and use instructions should be followed.
5. Water and Moisture - The appliance should not be used near water - for example, near a bathtub, washbowl, kitchen sink, laundry tub, in a wet basement, or near a swimming pool, and the like.
6. Carts and Stands - The appliance should be used only with a cart or stand that is recommended by the manufacturer.



An appliance and cart combination should be moved with care. Quick stops, excessive force, and uneven surfaces may cause the appliance and cart combination to overturn.

7. Wall or Ceiling Mounting - The appliance should be mounted to a wall or ceiling only as recommended by the manufacturer.
8. Ventilation - The appliance should be situated so that its location or position does not interfere with its proper ventilation. For example, the appliance should not be situated on a bed, sofa, rug, or similar surface that may block the ventilation openings; or, placed in a built-in installation, such as a bookcase or cabinet that may impede the flow of air through the ventilation openings.
9. Heat - The appliance should be situated away from heat sources such as radiators, heat registers, stoves, or other appliances (including amplifiers) that produce heat.

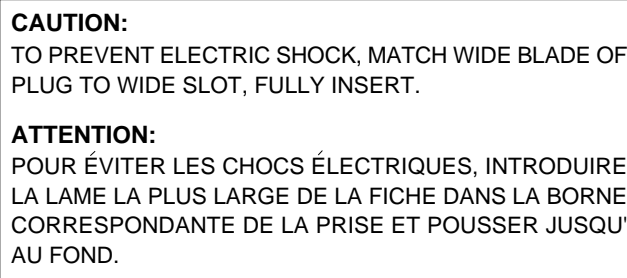

The lightning flash with arrowhead symbol, within an equilateral triangle, is intended to alert the user to the presence of uninsulated "dangerous voltage" within the product's enclosure that may be of sufficient magnitude to constitute a risk of electric shock to persons.



The exclamation point within an equilateral triangle is intended to alert the user to the presence of important operating and maintenance (servicing) instructions in the literature accompanying the appliance.

10. Power Sources - The appliance should be connected to a power supply only of the type described in the operating instructions or as marked on the appliance.
11. Grounding or Polarization - The precautions that should be taken so that the grounding or polarization means of an appliance is not defeated.
12. Power Cord Protection - Power supply cords should be routed so that they are not likely to be walked on or pinched by items placed upon or against them, paying particular attention to cords at plugs, convenience receptacles, and the point where they exit from the appliance.
13. Cleaning - The appliance should be cleaned only as recommended by the manufacturer.
14. Nonuse Periods - The power cord of the appliance should be unplugged from the outlet when left unused for a long period of time.
15. Object and Liquid Entry - Care should be taken so that objects do not fall and liquids are not spilled into the enclosure through openings.
16. Damage Requiring Service - The appliance should be serviced by qualified service personnel when:
 - A. The power supply cord or the plug has been damaged; or
 - B. Objects have fallen, or liquid has been spilled into the appliance; or
 - C. The appliance has been exposed to rain; or
 - D. The appliance does not appear to operate normally or exhibits a marked change in performance; or
 - E. The appliance has been dropped, or the enclosure damaged.
17. Servicing - The user should not attempt to service the appliance beyond that described in the operating instructions. All other servicing should be referred to qualified service personnel.
18. The appliance should be situated away from drops of water or spray of water.
19. Objects containing liquid such as vase must not be put on the appliance.
20. The appliance is not completely isolated from the power supply even if the power switch is at off position.

Names and functions

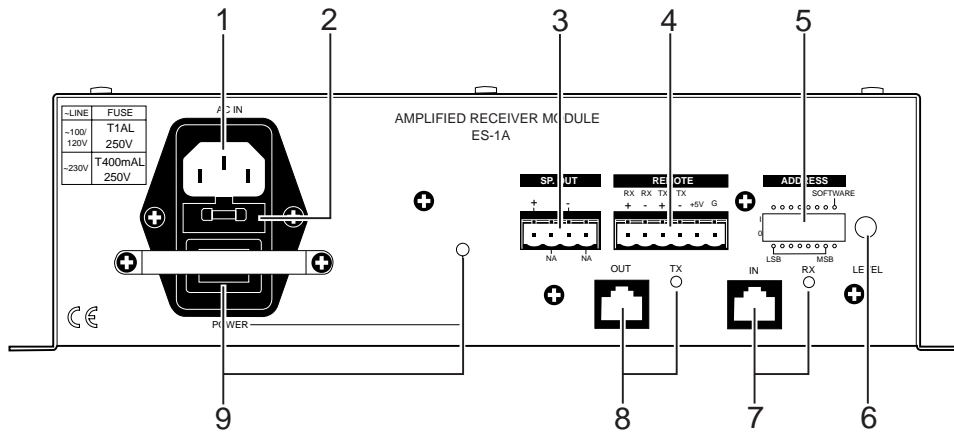

1) AC IN connector

This connector is used to connect the supplied AC cord.

2) Fuse box

This box houses a protection fuse.

3) SP OUT (EURO 4-pin connector)

This connector is used to connect external speaker units. The applicable load impedance is 8 to 16 ohms. The maximum output power is 20 W/8 ohms with the ES-1A (mono) or 10 W/8 ohms with the ES-2A (stereo). On the ES-2A the "A" connections feeds the audio signal of the selected channel, while the "B" connections feeds the audio signal of the next channel up from the selected channel in hardware mode. If in software mode or when using the optional local remote control (available soon), A & B channel assignments of ES-2A can be 'freemform'.

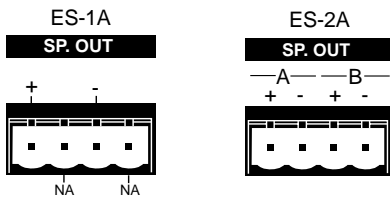

4) REMOTE connector (EURO 6-pin connector)

This connector is used to connect to the optional remote controller (available soon). See the specification for the pin assignment.

5) DIP switches

You can set the address (output channel) of the unit using DIP switches #1 through #7. When switch #8 is set to "1" (software), the address is controlled externally and the setting of DIP switches #1 through #7 is ignored.

6) Level control

Used to adjust the output level of the internal power amplifier. If you adjust the pot to the center click point, the unit outputs the maximum power at 0 dB (=digital full scale). If you adjust it to the max. point, the unit output the maximum power at -12 dB (digital scale).

7) IN port (RJ-45)

This port is used to connect the unit to another NetCIRA unit or 100baseTX switching hub by using a LAN cable (see the connection example below). While the unit receives data, the RX indicator lights up.

8) OUT port (RJ-45)

This port is used to connect the unit to another NetCIRA unit or 100baseTX switching hub by using a LAN cable (see the connection example below). While the unit transmits data, the TX indicator lights up.

9) POWER switch

Turns on or off the main power of the unit.

Connecting examples

Daisy Chain connection

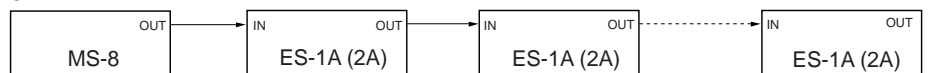

Mixed Star & Daisy Chain connection

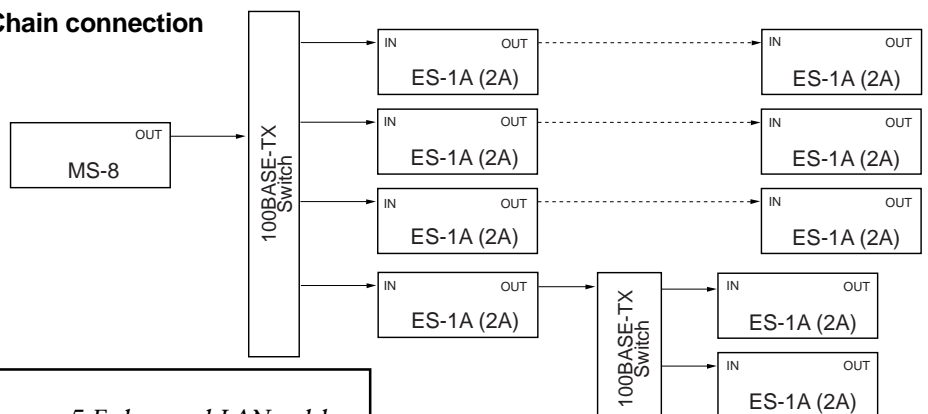

<Note>
Use "straight" category 5 Enhanced LAN cables.

DIP switch settings

Switch 1~7

1	2	3	4	5	6	7	ES-1A	ES-2A
0	0	0	0	0	0	0	1ch	1, 2ch
1	0	0	0	0	0	0	2ch	2, 3ch
0	1	0	0	0	0	0	3ch	3, 4ch
1	1	0	0	0	0	0	4ch	4, 5ch
0	0	1	0	0	0	0	5ch	5, 6ch
1	0	1	0	0	0	0	6ch	6, 7ch
0	1	1	0	0	0	0	7ch	7, 8ch
1	1	1	0	0	0	0	8ch	8, 9ch
0	0	0	1	0	0	0	9ch	9, 10ch
1	0	0	1	0	0	0	10ch	10, 11ch
0	1	0	1	0	0	0	11ch	11, 12ch
1	1	0	1	0	0	0	12ch	12, 13ch
0	0	1	1	0	0	0	13ch	13, 14ch
1	0	1	1	0	0	0	14ch	14, 15ch
0	1	1	1	0	0	0	15ch	15, 16ch
1	1	1	1	0	0	0	16ch	16, 17ch
0	0	0	0	1	0	0	17ch	17, 18ch
1	0	0	0	1	0	0	18ch	18, 19ch
0	1	0	0	1	0	0	19ch	19, 20ch
1	1	0	0	1	0	0	20ch	20, 21ch
0	0	1	0	1	0	0	21ch	21, 22ch
1	0	1	0	1	0	0	22ch	22, 23ch
0	1	1	0	1	0	0	23ch	23, 24ch
1	1	1	0	1	0	0	24ch	24, 25ch
0	0	0	1	1	0	0	25ch	25, 26ch
1	0	0	1	1	0	0	26ch	26, 27ch
0	1	0	1	1	0	0	27ch	27, 28ch
1	1	0	1	1	0	0	28ch	28, 29ch
0	0	1	1	1	0	0	29ch	29, 30ch
1	0	1	1	1	0	0	30ch	30, 31ch
0	1	1	1	1	0	0	31ch	31, 32ch
1	1	1	1	1	0	0	32ch	32, 33ch
0	0	0	0	0	1	0	33ch	33, 34ch
1	0	0	0	0	1	0	34ch	34, 35ch
0	1	0	0	0	1	0	35ch	35, 36ch
1	1	0	0	0	1	0	36ch	36, 37ch
0	0	1	0	0	1	0	37ch	37, 38ch
1	0	1	0	0	1	0	38ch	38, 39ch
0	1	1	0	0	1	0	39ch	39, 40ch
1	1	1	0	0	1	0	40ch	40, 41ch
0	0	0	1	0	1	0	41ch	41, 42ch
1	0	0	1	0	1	0	42ch	42, 43ch
0	1	0	1	0	1	0	43ch	43, 44ch
1	1	0	1	0	1	0	44ch	44, 45ch
0	0	1	1	0	1	0	45ch	45, 46ch
1	0	1	1	0	1	0	46ch	46, 47ch
0	1	1	1	0	1	0	47ch	47, 48ch
1	1	1	1	0	1	0	48ch	48, 49ch
0	0	0	0	1	1	0	49ch	49, 50ch
1	0	0	0	1	1	0	50ch	50, 51ch
0	1	0	0	1	1	0	51ch	51, 52ch
1	1	0	0	1	1	0	52ch	52, 53ch
0	0	1	0	1	1	0	53ch	53, 54ch
1	0	1	0	1	1	0	54ch	54, 55ch
0	1	1	0	1	1	0	55ch	55, 56ch
1	1	1	0	1	1	0	56ch	56, 57ch
0	0	0	1	1	1	0	57ch	57, 58ch
1	0	0	1	1	1	0	58ch	58, 59ch
0	1	0	1	1	1	0	59ch	59, 60ch
1	1	0	1	1	1	0	60ch	60, 61ch
0	0	1	1	1	1	0	61ch	61, 62ch
1	0	1	1	1	1	0	62ch	62, 63ch
0	1	1	1	1	1	0	63ch	63, 64ch
1	1	1	1	1	1	0	64ch	64ch, -

Switch 8

8	ES-1A/ES-2A
0	hardware (The output channel is set by switches #1 through #7.)
1	software (The output channel is controlled externally.)

Specifications

<Audio section>

Output connector:	ES-1A; EURO 4-pin (mono output between BTL+ and BTL-) ES-2A; EURO 4-pin (L and R)
Adaptable impedance:	8Ω - 16Ω
Reference level:	-12dB
Output level:	ES-1A; 20 +/-3W (8Ω load, 1kHz, -12dB Full Scale level, VR: max) ES-2A; 10 +/-3W (8Ω load, 1kHz, -12dB Full Scale level, VR: max)
Residual noise:	-70dBV or less (DIN AUDIO)
THD:	0.1% or less at 7W/8Ω (ES-2A) 0.1% or less at 15W/8Ω (ES-1A)
Frequency response:	+/-3dB at 20Hz - 20kHz

<Network interface section>

IN port connector:	RJ-45
OUT port connector:	RJ-45
Cable length:	100m or less
Media:	100BASE-TX
Protocol:	Digigram EtherSound

<Control interface section>

To connect LR-1 (tentative) for level & CH controlling	
Remote connector:	EURO 6-pin
<Pin assignments>	
	1: RX (+), 2: RX (-), 3: TX (+)
	4: TX (-), 5: +5V, 6: GND
Protocol:	RS422

<General>

Dimensions (mm):	280 (W) x 77 (H) x 160 (D)
Power supply:	Transformer type
Power requirement:	JPN AC100V 50/60Hz US 120VAC 60Hz EUR/UK 230V ~ 50Hz
Power consumption:	23W (ES-2A), 26W (ES-1A)
Weight:	Approx. 2.7kg

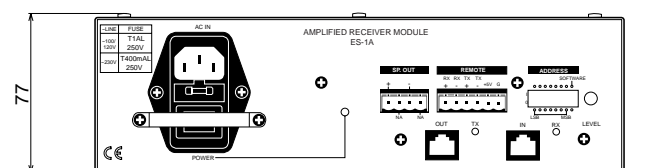
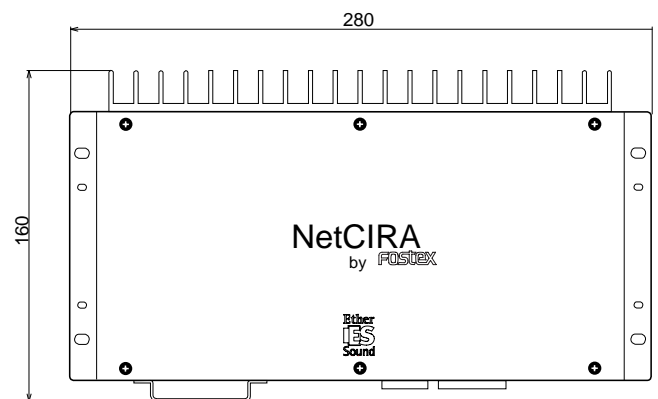

Declaration of EC Directive

This equipment is compatible with the EMC Directive (89/336/EEC) - Directive on approximation of member nation's ordinance concerning the electromagnetic compatibility. This equipment is compatible only when connected to fostex specified product.

The Affect of Immunity on this Equipment

Please comply to the precautions below to make this equipment compatible with European Specification EN61000-6-1 (coexistence of electromagnetic waves - common immunity specification).

In the electrical fast transient/burst requirements, surge, conducted disturbances by radio-frequency fields, power frequency magnetic field, radiate electromagnetic field requirements and static electricity discharging environment, this could be affected by generation of noise in some cases.

NetCIRA
by **FOSTEX**

FOSTEX CO.

3-2-35 Musashino, Akishima-shi, Tokyo, Japan 196-0021